



Hafif Çelik Profil Çekme Kabiliyetimiz

Kalınlık : 0,6mm'den 1.60mm'ye kadar özel şekillendirmiş C ve U Profillerden duvar ve makas panelleri üretilmektedir.



SECTION PROCESSES

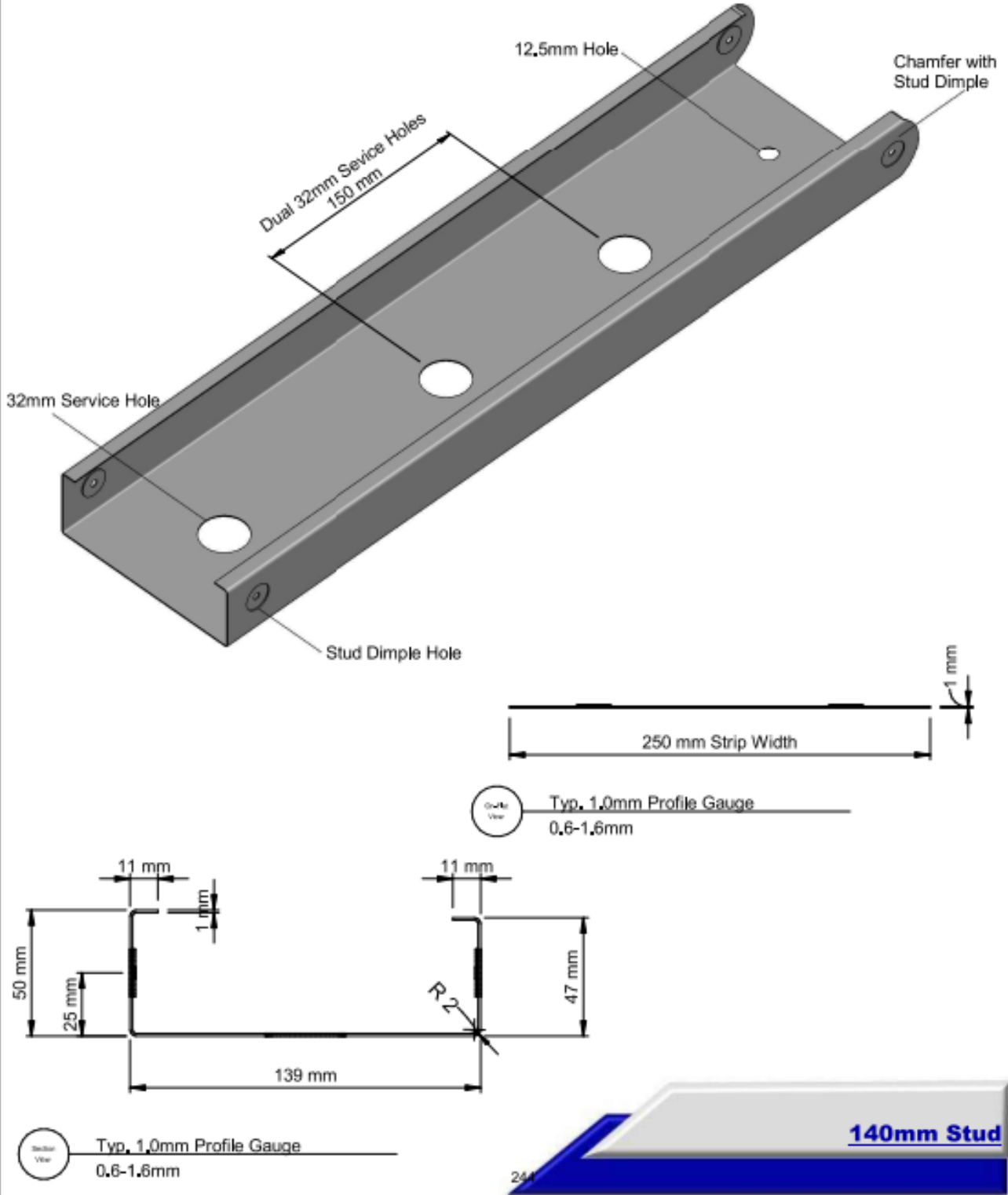



SECTION PROCESSES

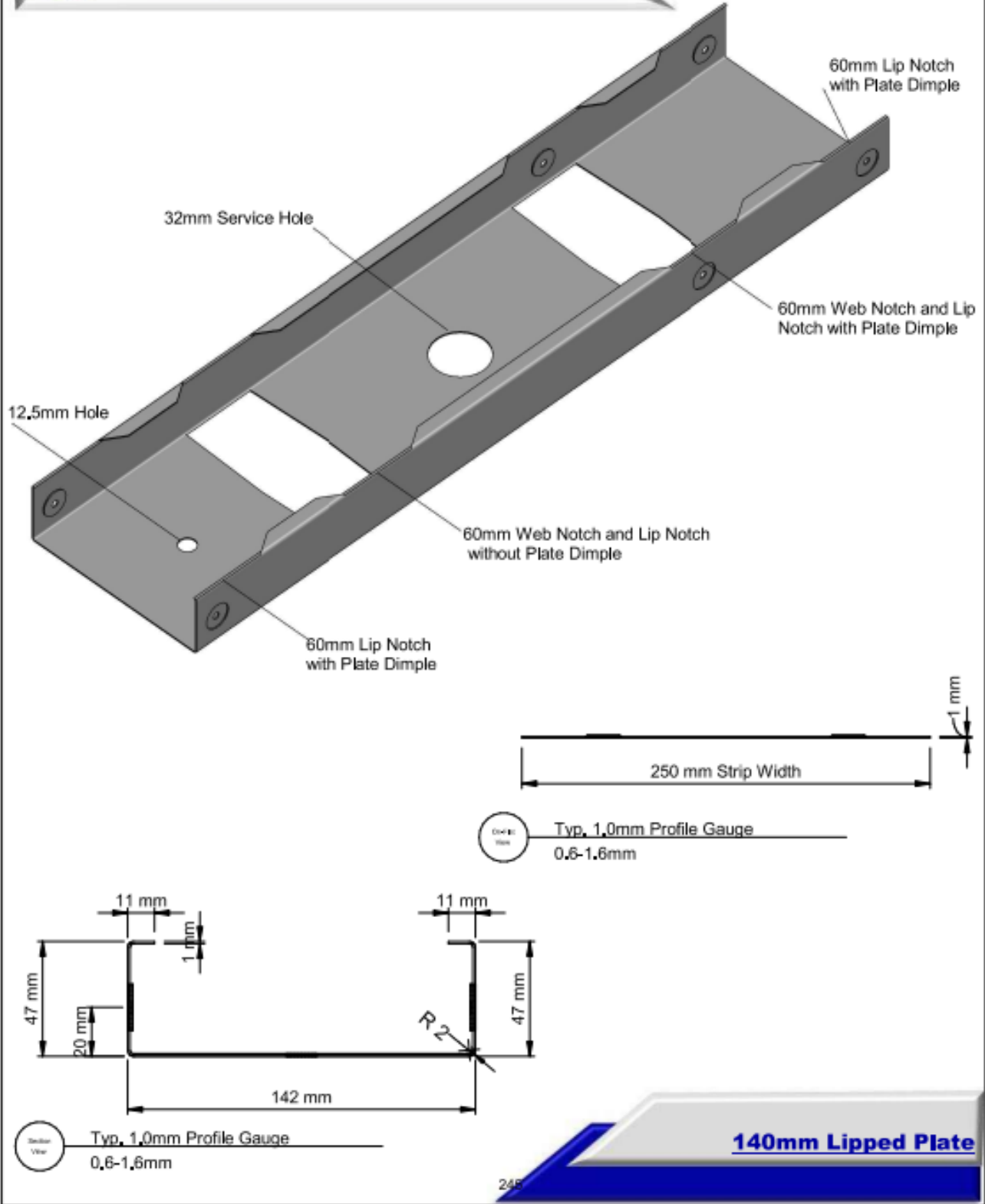



SECTION PROCESSES

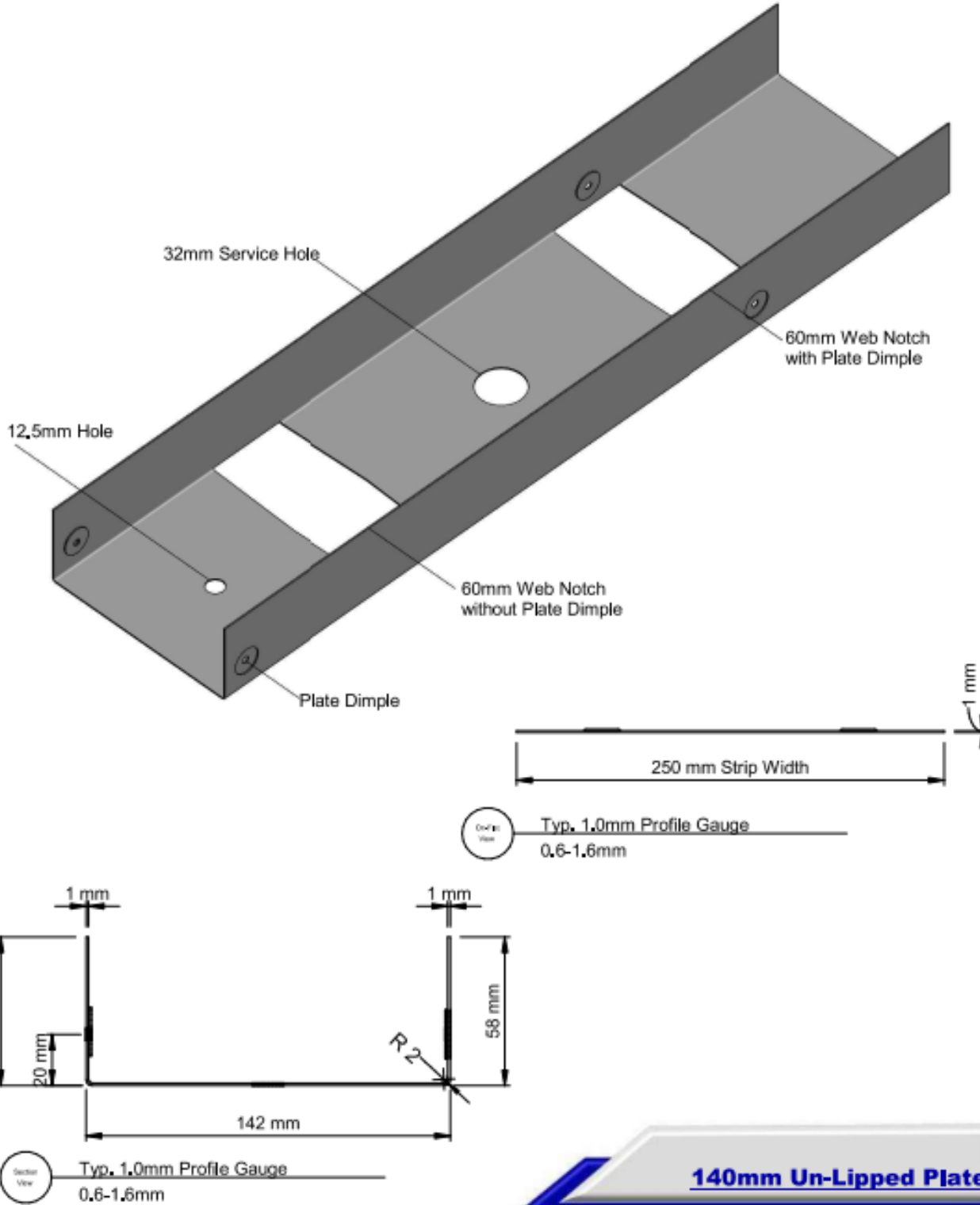



SECTION PROCESSES

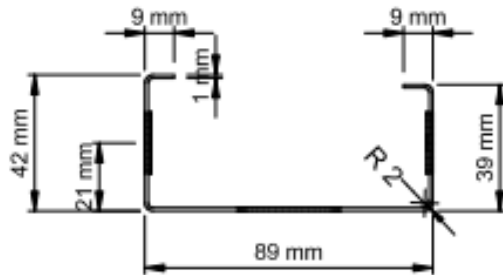
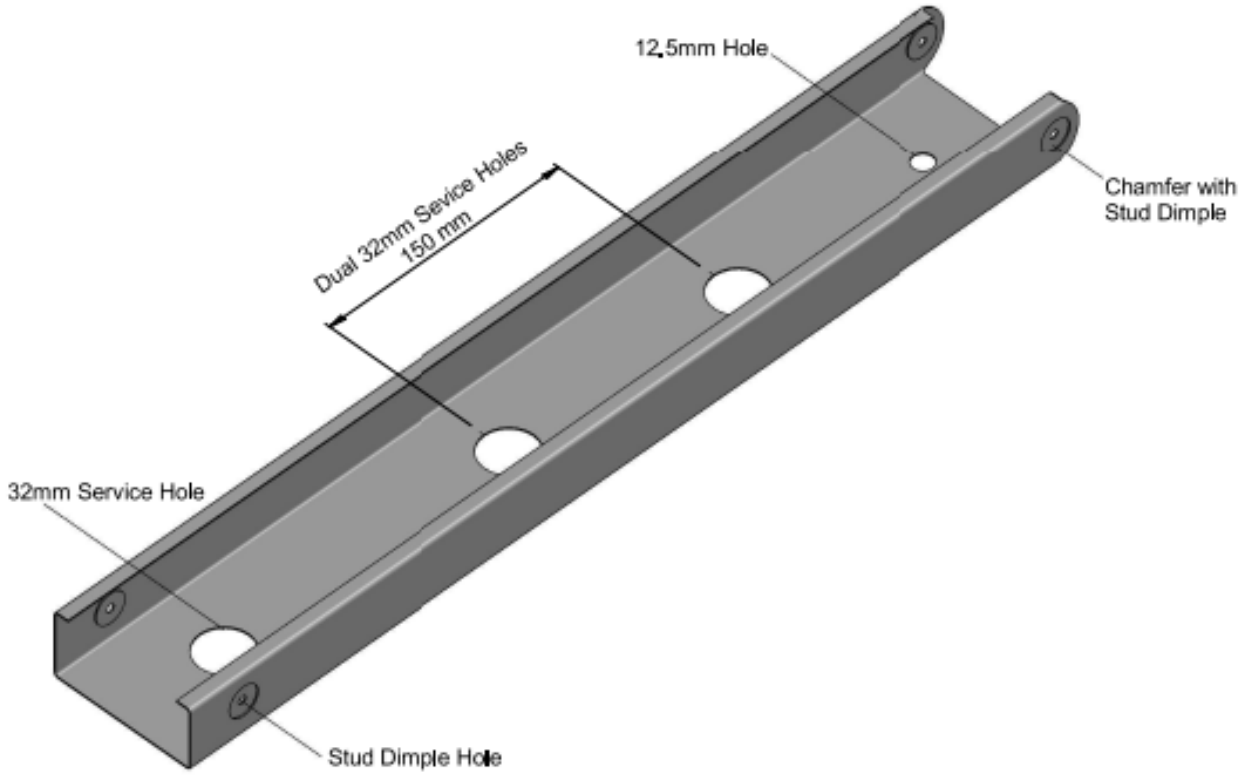

Section View Typ. 1.0mm Profile Gauge 0.6-1.6mm

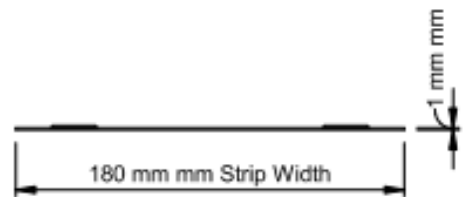

Circle View Typ. 1.0mm Profile Gauge 0.6-1.6mm

90mm Stud

247



SECTION PROCESSES

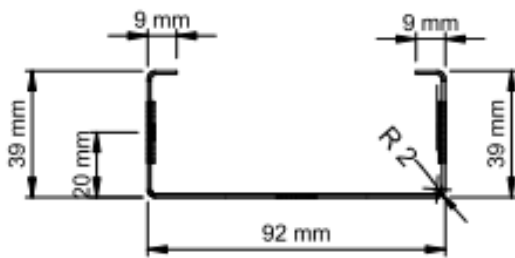
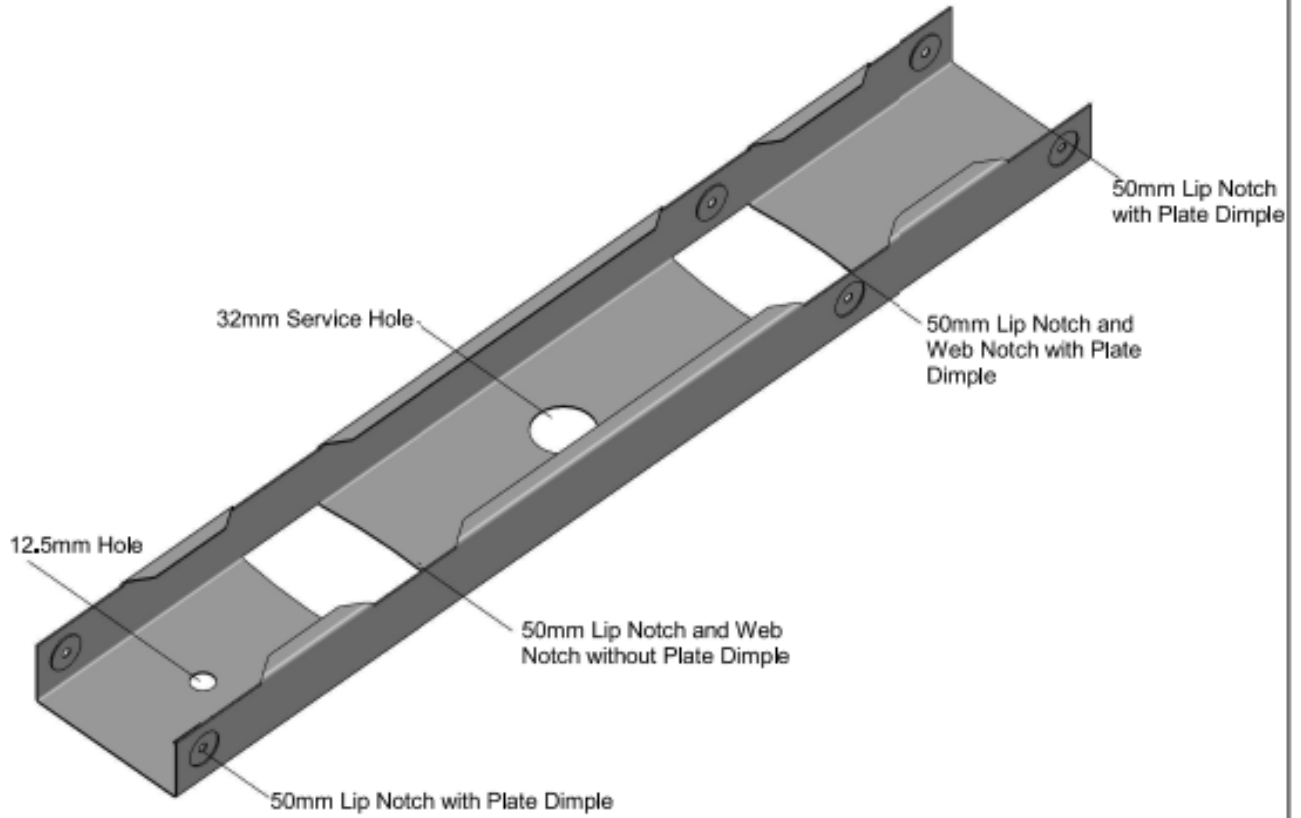

Section View
Typ. 1,0mm Profile Gauge
0,6-1,6mm

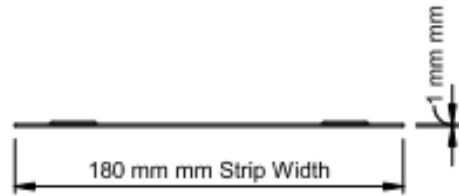

Strip View
Typ. 1,0mm Profile Gauge
0,6-1,6mm

90mm Lipped Plate



SECTION PROCESSES

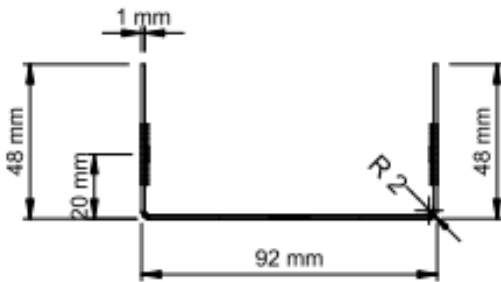
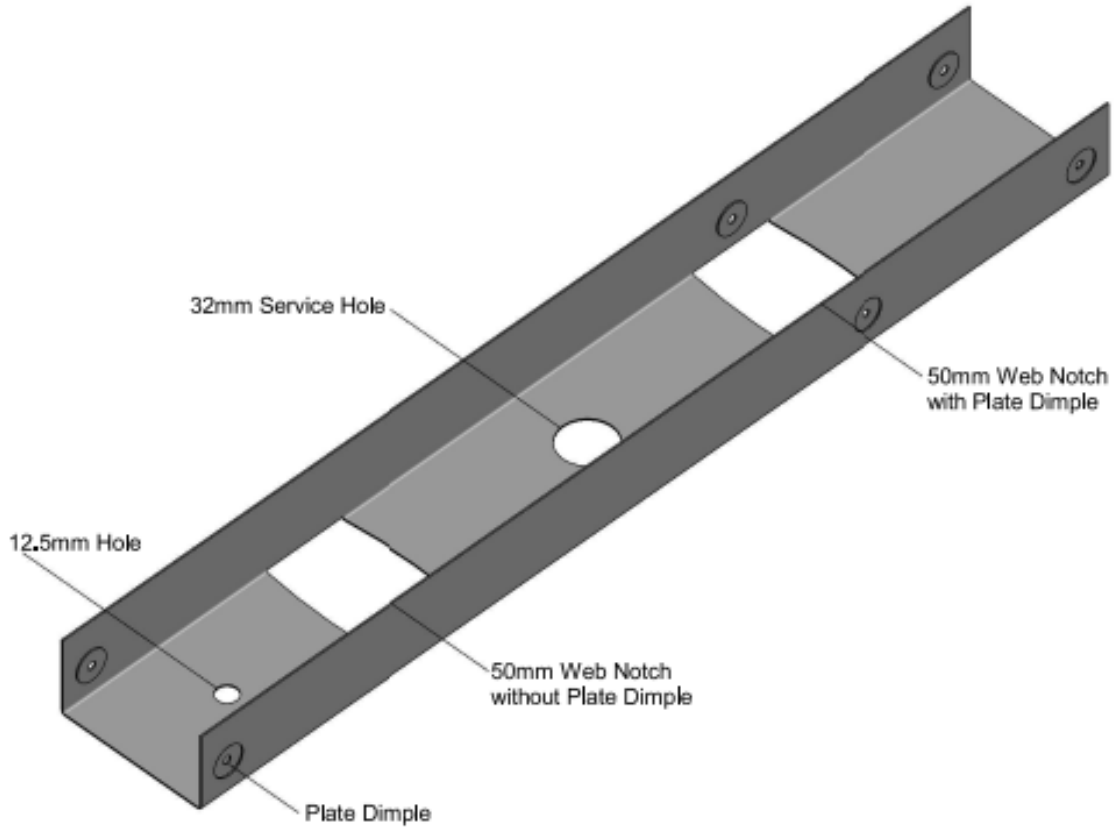

Bottom View Typ. 1,0mm Profile Gauge 0,6-1,6mm

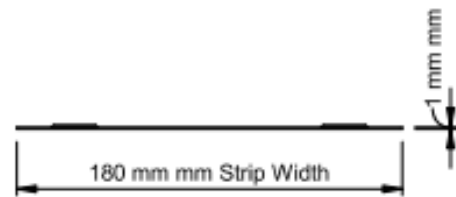

Outer View Typ. 1,0mm Profile Gauge 0,6-1,6mm

90mm Un-Lipped Plate



SECTION PROCESSES

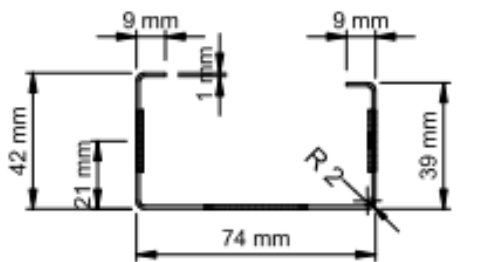
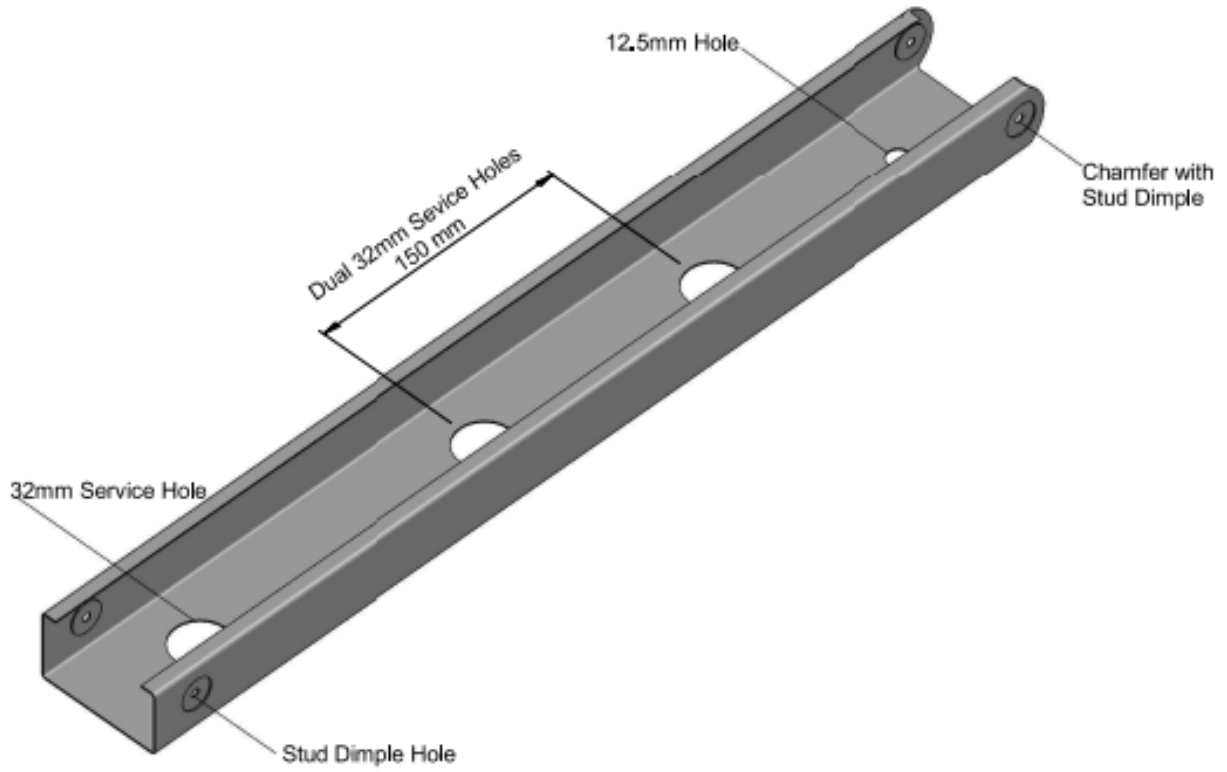

Section View Typ. 1,0mm Profile Gauge 0,6-1,6mm

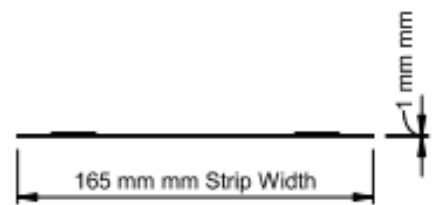

Strip View Typ. 1,0mm Profile Gauge 0,6-1,6mm

75mm Stud

258



SECTION PROCESSES

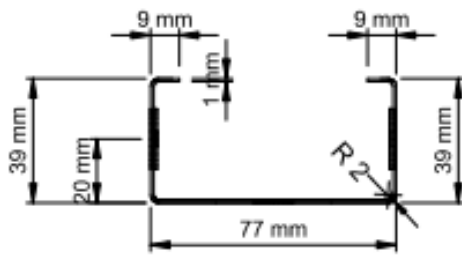
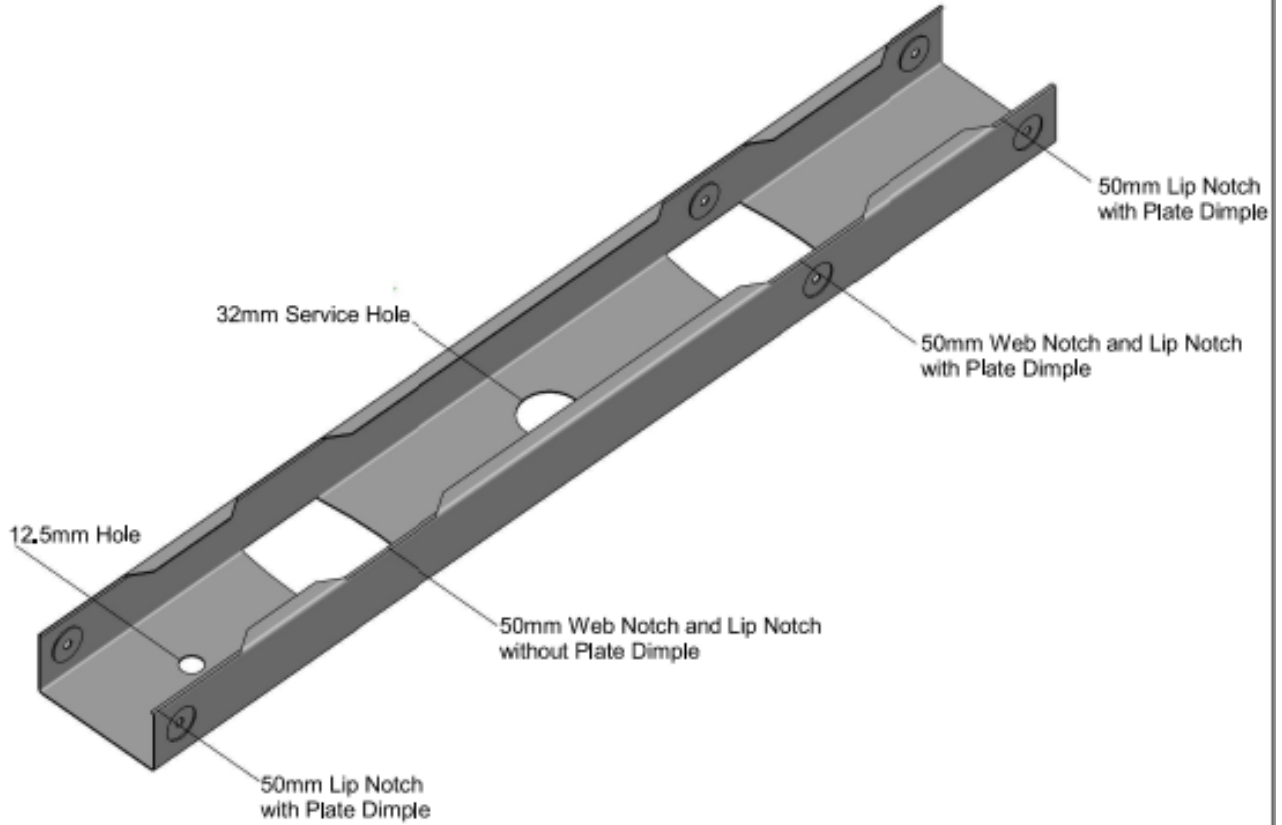

Section View Typ. 1.0mm Profile Gauge 0.6-1.6mm

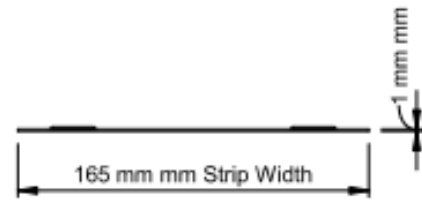

Circle View Typ. 1.0mm Profile Gauge 0.6-1.6mm

75mm Lipped Plate



SECTION PROCESSES

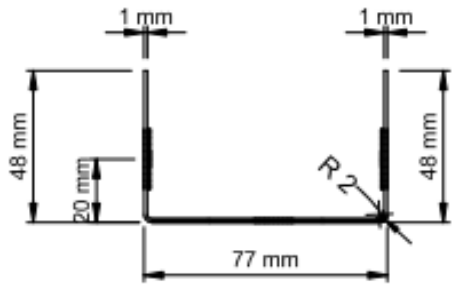
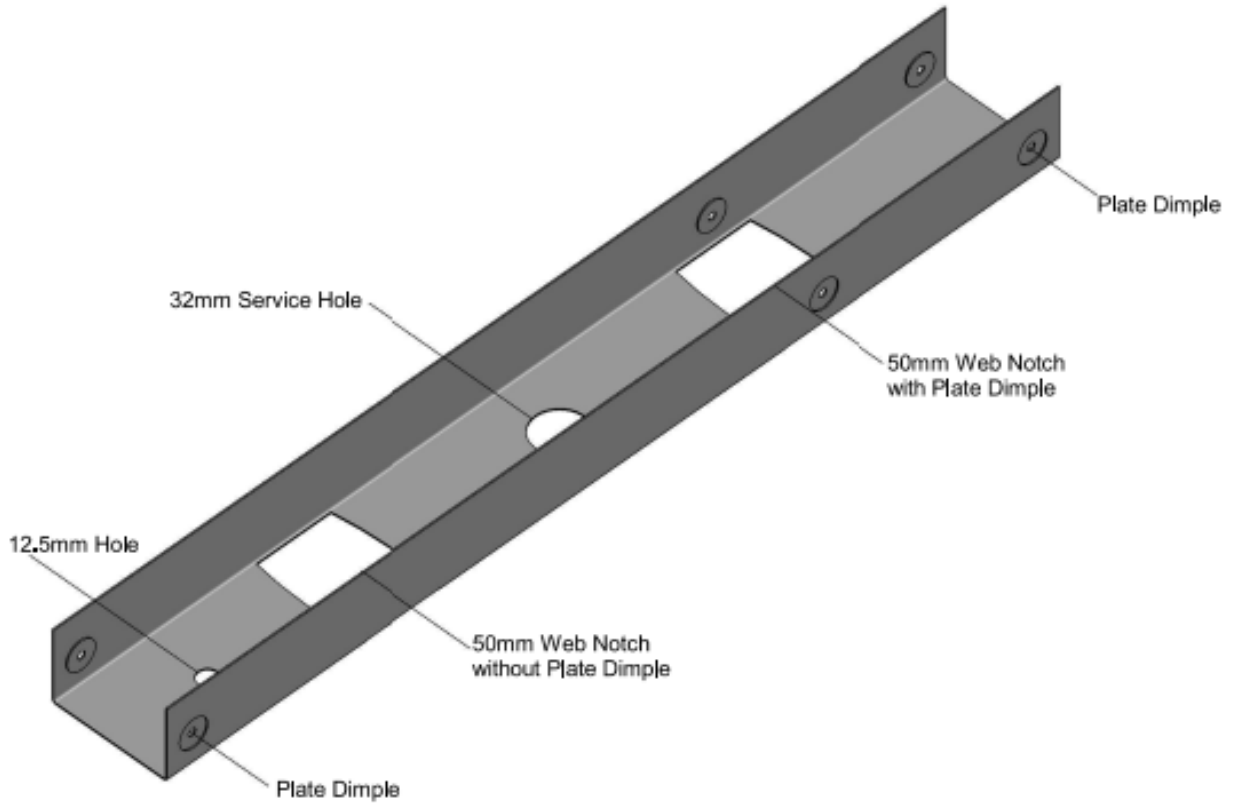

Section View
Typ. 1,0mm Profile Gauge
0,6-1,6mm



Side View
Typ. 1,0mm Profile Gauge
0,6-1,6mm

75mm Un-Lipped Plate



SECTION PROCESSES

Tolerances	
All dimensions are nominal unless otherwise stated.	
Below table should be used to determine if the dimensions falls within tolerances, unless otherwise noted.	
A	$\pm 1.00\text{mm}$
B	$\pm 1.50\text{mm}$
C	$\pm 1.50\text{mm}$
D1 minus D2	$\leq 1.50\text{mm}$
E1 minus E2	$\leq 2.00\text{mm}$
ANGLE	$\pm 2^\circ$ (degrees)
BOW	6mm MAX PER 1000mm LENGTH OF PART, IN EITHER DIRECTION
CAMBER	6mm MAX PER 1000mm LENGTH OF PART, IN EITHER DIRECTION
TAPER	$\leq 2.00\text{mm}$
END FLARE	TO BE KEPT TO A MINIMUM - SHOULD NOT HINDER ASSEMBLY
NOTE: ALL DIMENSIONS ARE TO BE MEASURED 200mm FROM THE THE ENDS TO ACCOUNT FOR END FLARE	

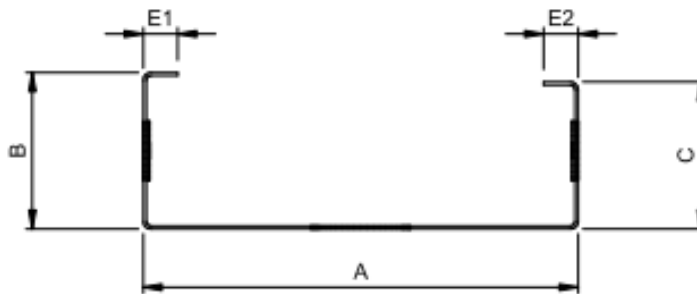

General Tolerances

255